

30" Commercial DC Wall Fan

Installation / User Manual

fanco 

Wall fan instruction booklet

Thank you for purchasing your Fanco 30" Commercial DC Wall Fan. Please read all instructions carefully before assembly and use.

IMPORTANT SAFEGUARDS

Read all instructions carefully, even if you feel you are quite familiar with this type of appliance. When using electrical appliances, in order to reduce the risk of fire, electric shock, and/or injury, these basic safety precautions should always be followed:

1. Use this fan only as described in this manual. Any other use not recommended by the manufacturer may cause fire, electric shock, or injury to persons and may void the warranty. Improper installation may result in the risk of fire, electric shock, or injury to persons.
2. This appliance is not intended for use by persons (including children) with reduced physical, sensory or mental capabilities, lack of experience and knowledge, unless they have been given supervision or instruction concerning the use of the appliance by a person responsible for their safety.
3. Children should be supervised to ensure that they do not play with the appliance.
4. The installation of a residual current device (safety switch) is recommended to provide additional safety protection when using electrical appliances.
5. Remove the product from packaging and check all components are in good condition before use. Do not use the fan if you find a damaged part.
6. Ensure that the fan is switched off from the supply mains before any maintenance, assembly, or disassembling parts.
7. If unusual oscillating movement is observed, immediately stop using the fan and contact the manufacturer, its service agent or suitably qualified persons.
8. If the supply cord is damaged, it must be replaced by the manufacturer, its service agent or similarly qualified persons in order to avoid a hazard.
9. This product is for indoor use only. Do not place the fan in or near an open window, rain and other weather elements may cause an electrical hazard.
10. Do not immerse or expose the product to water, moisture or other liquids.
11. Never insert fingers or any object through the guards.
12. Make sure your hands are dry before operating the electrical appliance.
13. Do not cover the product, or use the product near curtains.
14. Caution! Risk of electric shock: Do not attempt to open any part of the motor housing, as a risk of electrical shock may exist.

IMPORTANT NOTE:

The important safeguards and instructions given in this manual are not meant to cover all possible conditions and situations that may occur. It must be understood that common sense, caution and care are factors which cannot be built into any product.

Model Number	Rated Voltage	Rated DC Motor Power	Blade Size	Weight	Controller
PWFC750DC	220-240 V AC	Max. 170W DC motor	30 inches	10.4 kg	5 Speed digital controller with timer

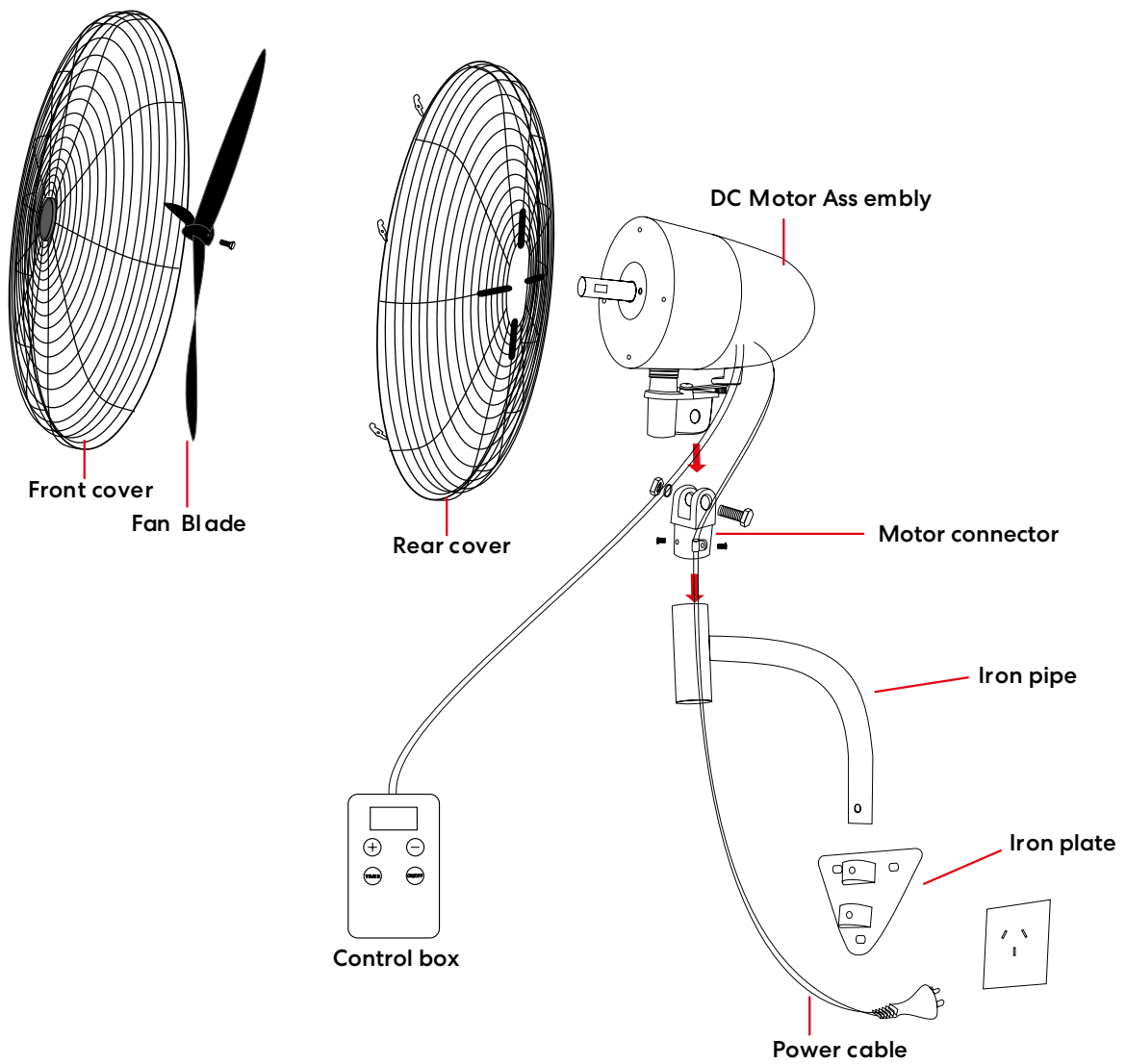

INSTALLATION AND ASSEMBLY

SELECTING A LOCATION

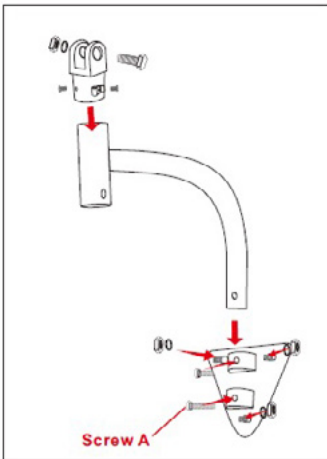

1. Choose a location for mounting mounting plate, where the structure is capable of carrying a load of at least 60 kg, with mounting screws or bolts and nuts (not provided). Customer needs to purchase mounting screws and bolts depending on the structure and material of mounting surface.

2. Insert mounting pipe into the mounting plate. Align the hole on the pipe with bottom screw on the mounting plate. Secure the pipe by tighten 2 screws on the mounting plate.

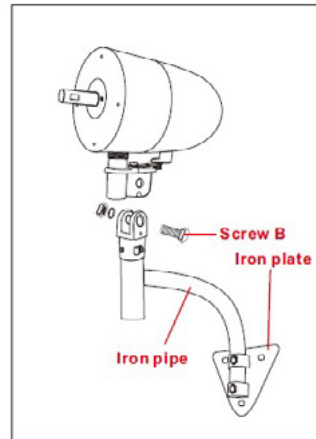

3. Take off the bolt, washer and nut from the top of the pipe. Place the motor on the pipe and fix the motor securely on the pipe with the bolt, nut and washer.

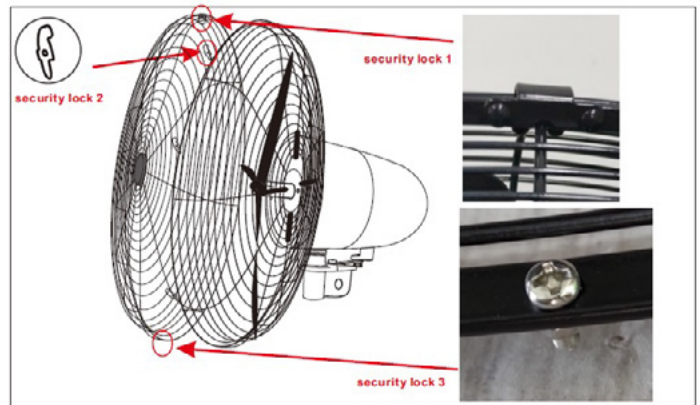

6. Align the top security hook the top center of the rear cage. Match screw holes of front and rear cages together. Secure the front and rear cages together by pressing security locks.

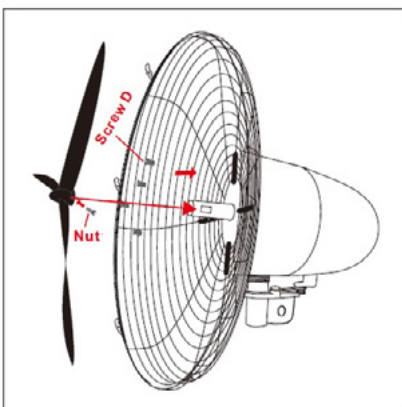

4. Loosen the rear cage locking screws from the motor. Place the rear cage over the motor shaft. Align screw holes of rear cage with holes on the motor and secure the rear cage by screws taken off from the motor.

5. Place the blade onto the motor shaft and fasten it by tightening the blade locking screw on the blade.

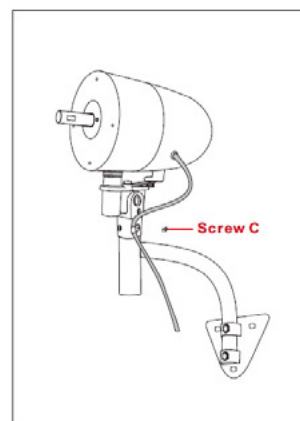

7. Screw cable clamps on the mounting pipe. **IMPORTANT: check if the length of the cable is sufficient for oscillation before turn on the fan! Protect the cable from strain!**

OPERATING INSTRUCTIONS

1. Press the ON/OFF button to switch the fan on or off.
2. Choose a speed setting from 1-5 (1 Slowest & 5 Fastest) by pressing the “+” or “-” buttons.
3. Press TIMER button to start or cancel countdown timer. Adjust desired hours (between 1 to 8 hours) for timer setting by pressing the “+” or “-” buttons when timer display is on.
4. Adjust screw on the bottom of the motor to choose either fixed (forward facing) or oscillation.

Position 1: Fixed - forward facing

Position 2: Oscillation (Note: side screw must be tightened for oscillation)

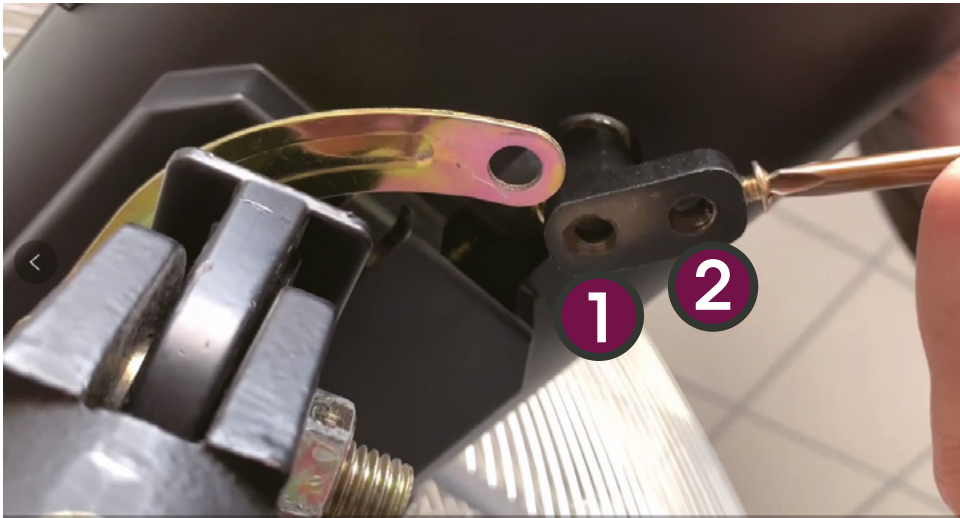

Note:

Display goes into sleep mode after 3 seconds if no control. To wake up display and see current status of the fan, simply press any button.

Fan memories last operating setting of the fan before power is cut off, including speeds, on/off.

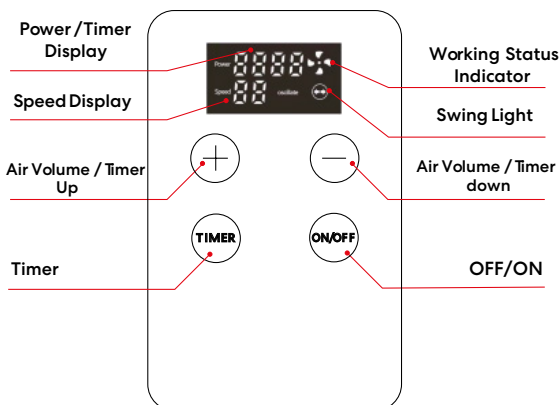

MAINTENANCE INSTRUCTIONS

1. Periodic cleaning of your fan is the only maintenance required (approximately every 6 months).
2. **WARNING!** Ensure that the fan is switched off from the power source before removing the guard.
3. Remove the guards and the blade, and be careful to not drop the blade!
4. Use a soft cloth with mild soap to clean off any dust or stains, then wipe with a dry cloth.
5. Never use polish or corrosive liquids as this will damage the paint, metal or plastic!
6. Put the blade back and lock the guard securely before use.
7. Reconnect the power cord.

WARRANTY

The benefits conferred by this express Fanco warranty are optional and are in addition to all relevant implied warranties, rights and remedies available under Australian Consumer Law. If you encounter issues with the fan during installation, Fanco highly recommends to contact Fanco for trouble shooting assistance if the installation is during business hours on 03 8658 9588 or to service@fanco.com.au.

Warranty details:

Manufacturer's warranty covers a full replacement for the defect product only. It does not cover defects within the fan installation or improper maintenance.

Warranty Period:

The warranty period for this product is 12 months.

The warranty period begins from the date of purchase, as determined by the tax invoice provided by the authorised retailer.

Warranty Limitations and Conditions:

Proof of Purchase – Proof of purchase from an authorised retailer specifying the fan model and purchase date (such as a tax invoice) must be supplied for the warranty claim to be processed.

Outdoor use – This product is not intended or recommended for, and is therefore not warranted for use outdoors including covered and/or enclosed al fresco areas. The warranty does not cover rust or damage caused by rust to the motor and fan components.

Reasonable wear and tear – is not covered by warranty. The client should ensure the fan is regularly cleaned and any screws and blade nuts that become loose through normal operation are tightened. This is not covered by warranty.

Domestic/Personal Use only - This product is not designed or intended for industrial or commercial use and therefore the warranty will not cover such use.

Purchase from Authorised Retailer – In order for the warranty to apply, the Fanco fan must have been purchased in Australia from an authorised retailer (please see the Fanco website for a list of authorised retailers).

Fanco Warranty Applies in Australia Only – Fanco warranty is only available for products installed and being used in Australia.

Incorrect Installation/Misuse/damage of product – is not covered by warranty. The Fanco fan must be installed and used according to the installation manual and user guidelines. Damage caused by external factors such as (but not limited to) power supply faults/surges, water damage, lighting and other Acts of God is not covered by this warranty. Fanco fans must only be installed and used with compatible accessories as specified by Fanco. Use with or wiring with non-authorised accessories and/or other items will void this warranty. If a Fanco Service Agent determines a problem with the product is due to incorrect installation or misuse of the product, the product will not be replaced. Fanco does not accept liability for any direct or consequential damage, loss or other expense arising from misuse or incorrect installation and operation of the appliance.

Warranty Claims

You can claim the warranty at the place you purchased fan or to Fanco directly.

Replace product at place of purchase.

Bring the defect products and proof of purchase to the place of purchase.

Contact Fanco directly

Please submit any warranty claims in writing by one of the following methods;

1. Email to: **service@fanco.com.au** and attaching the required documents
2. Filling out the warranty claim form on the Fanco website and attaching the required documents

Please ensure all warranty claims are in accordance with the warranty conditions and limitations outlined above and that you include proof of purchase

Please allow up to four days from receipt of your warranty claim for a response.

Our goods come with guarantees that cannot be excluded under the Australian Consumer Law. You are entitled to a replacement or refund for a major failure and compensation for any other reasonably foreseeable loss of damage. You are also entitled to have the goods repaired or replaced if the goods fail to be of acceptable quality and the failure does not amount to a major failure.

Fanco

18 Cleeland Road

Oakleigh South, VIC 3167

<https://www.fanco.com.au/>

Tel: 03 8658 9588

Email: service@fanco.com.au

fanco●